



Translation of the
Original Operating Instructions
perma
STAR CONTROL IMPULSE

This operating manual is valid for the lubricator
perma STAR CONTROL IMPULSE in sizes S60, M120 and L250.

© 2006 perma-tec GmbH & Co. KG

Without the specific approval of perma-tec GmbH & Co. KG no part of this documentation can be copied or made available to third parties.

We have taken great care when compiling all the details contained in this documentation. However we cannot rule out discrepancies and we reserve the right to make technical changes to the product without giving advance notice.

We do not assume any judicial responsibility or liability for damages which may ensue as a result.

We will include any necessary changes in the next edition.

Compiled and printed: 11 / 02 / 2009

Table of Contents

1	VARIOUS	1
1.1	About this operating manual	1
1.1.1	Terms used	1
1.1.2	Usage of safety instructions	1
1.1.3	Danger signs	1
1.1.4	Tips	1
1.2	Delivery	2
1.3	Lubricator perma STAR CONTROL IMPULSE	2
1.3.1	Markings	2
1.3.2	Intended usage	2
1.4	Legal requirements	3
1.4.1	Liability	3
1.4.2	Warranty	3
2	SAFETY INSTRUCTION	4
2.1	Persons responsible for safety	4
2.2	General safety informations	4
2.3	Safety information for perma STAR CONTROL IMPULSE	5
2.3.1	Safety during installation and maintenance	5
2.3.2	Safety when handling LC units	5
3	TECHNICAL DATA	6
3.1	Data sheet: power supply	6
3.1.1	Cable construction	6
3.1.2	Values	6
3.2	Product specifications	6
3.2.1	Pin assignment	6
3.2.2	Components	7
3.2.3	Airborne noise emission	7
3.2.4	Function	8
3.3	Weights and measurements	8
3.4	Operating conditions	9
3.4.1	Temperatures	9
3.4.2	Ambient conditions	9
4	STORAGE	9
4.1	General storage information	9
4.1.1	Ideal storage conditions	9
4.1.2	Storage periods	9

5	STARTING AND OPERATING	10
5.1	Preparation	10
5.2	Before operation	10
5.3	Initial operation	10
5.4	During operation	11
6	CHANGING THE LC UNIT	12
6.1	General note	12
6.2	How to change the LC unit	12
7	DRIVE UNIT SETTINGS	13
7.1	Function display	13
7.2	Circuit board settings	13
7.2.1	Setting discharge amount	14
7.2.2	Setting volume of LC unit	14
7.3	Table of discharge	15
7.3.1	Changing the discharge volume after the perma STAR CONTROL IMPULSE has been in operation/reset function	16
8	TROUBLE SHOOTING	17
9	DISPOSAL	18
10	ACCESSORIES FOR perma STAR CONTROL IMPULSE	18
10.1	Accessories	18
10.2	Replacement parts	18
11	SERVICE	18
12	SUGGESTION FOR PLC CONNECTION	19
12.1	Suggestion for PLC connection with one output signal	19
12.2	Suggestion for PLC connection with two output signals	20
12.3	Suggestion for PLC connection with three output signals	21

EC Declaration of Conformity

1 VARIOUS

1.1 About this operating manual

- ◆ This operating manual is intended for the safe operation of the perma STAR CONTROL IMPULSE automatic lubricator. It contains safety instructions which must be adhered to.
- ◆ Everyone who works on or with the lubricator must have access to this operating manual during their shift. They must also pay attention to all relevant instructions and notices.
- ◆ The operating manual must be kept in a complete and easy to read condition.

1.1.1 Terms used

◆ Lubricator

In the following text, the “lubricator” will either be called “lubricator” or by its name “perma STAR CONTROL IMPULSE”.

◆ Lubrication Canister

In the following text, the “Lubrication Canister” will be called LC unit.
The user can order the LC unit filled with different oils and greases and in sizes S60, M120, and L250.

1.1.2 Usage of safety instructions

All safety instructions in this operating manual are standardized.

1.1.3 Danger signs



Attention Danger!

This sign warns you of any danger to people’s health, life-threatening injuries and death.

1.1.4 Tips



This sign alerts you to application tips which will help you in doing certain things quicker and safer.

1.2 Delivery

- ◆ perma STAR CONTROL IMPULSE can be ordered and delivered according to customer specifications in regards to type of grease and oil, size / content of LC unit.
- ◆ Upon delivery, make sure to check if the delivered goods correspond to your order. perma-tec GmbH & Co. KG will not accept liability for subsequent claims of any shortcomings.
- ◆ Please immediately forward any claim
 - of noticeable transport damage: directly to the forwarder
 - of noticeable faults, shortcomings or defects: directly to your perma distributor.

1.3 Lubricator perma STAR CONTROL IMPULSE

1.3.1 Markings

- ◆ The lubricator perma STAR CONTROL IMPULSE is clearly marked with a label on the drive system and a label on the LC unit
- ◆ **CE Mark** on the drive unit
- ◆ Manufacturer:

perma-tec GmbH & Co. KG
Hammelburger Straße 21
97717 Euerdorf, Germany
Tel: +49 (0) 9704 609-0
Fax: +49 (0) 9704 609-50

E-mail: info@perma-tec.com
Homepage: www.perma-tec.com

1.3.2 Intended Usage

- ◆ The lubricator perma STAR CONTROL IMPULSE
 - supplies all lubrication points with oil and grease to a large extent continuously, precisely and temperature independent up to a pressure build-up of max **5 bar / 75 psi**; can be turned off and on via the machine (machine controlled).
 - can be used for all lubrication points of sliding- and roller bearings, drive- and transport chains, sliding guideways, open gears and seals.
 - is intended for use on machinery and equipment where lubrication is only to take place when the machine is running, and where a status report to the machine is desired.
 - is only to be used for the ordered purpose and purposes confirmed by perma-tec.

- is only to be used for operating conditions recommended in this operating manual.
- is only to be used with settings and variations recommended by this operating manual.



Any other usage, setting and variation is considered to be inappropriate.

1.4 Legal requirements

1.4.1 Liability

- ◆ The information, data and tips stated in this operating manual were up-to-date as of the printing date.
No claims for already delivered lubricators can be made based on the information, pictures and descriptions.
- ◆ perma-tec GmbH & Co. KG can not be held liable for damages and malfunctions caused by:
 - inappropriate usage;
 - unauthorized alterations to the drive system or the LC unit;
 - inappropriate operations on or with the lubricator;
 - incorrect operation and settings of the lubricator;
 - incorrect settings of time and size of the lubricator;
 - ignoring the operating manual.

1.4.2 Warranty

- ◆ Warranty terms and conditions: see terms and conditions of sale and delivery appertaining to perma-tec GmbH & Co. KG.
- ◆ Lodge any warranty claims with perma-tec immediately after the defect or error has been identified.
- ◆ The warranty expires in all instances where no liability claims can be enforced.

2 SAFETY INSTRUCTION

2.1 Persons responsible for safety

◆ Operator

- The operator is any individual or legal entity who or which uses the lubricator or on whose authority the lubricator is used.
- The operator or his safety officer must warrant,
 - that all the relevant regulations, instructions and laws are adhered to;
 - that only qualified personnel will work with and on the lubricator;
 - that the operating manual is made available to the personnel for all work done with and on the lubricator, and that the personnel adhere to it;
 - that unauthorized personnel are not allowed to work with and on the lubricator;
 - and that the safety regulations are adhered to when mounting the lubricator or during maintenance.

◆ Qualified personnel

Qualified personnel are persons who, by virtue of their training, experience, instruction and information concerning the relevant standards and provisions, accident prevention regulations and plant and operating conditions, as received from the person responsible for the safety of the plant, are entitled to carry out the activities required at any time so that any possible dangers or hazards can be identified and avoided.

2.2 General safety instructions

- ◆ We are not laying claim to completeness as regards these safety instructions. Please contact your local supplier if you have any queries or problems.
- ◆ At the time of delivery the lubricator is in line with state-of-the-art technology and in principle is considered to be safe to operate.
- ◆ Dangers emanate from the lubricator for persons, the lubricator itself and for other material assets of the operator if:
 - unqualified personnel operates the lubricator;
 - the lubricator is used inappropriately and for operations that it was not intended to be used for;
 - the lubricator setting / variation is incorrect.

- ◆ The lubricators must be filled with the correct oil or grease and must be set to operate correctly without causing any hazards to people when set, installed, and used for its intended purpose. This also pertains to their operation together with the complete machine and its lubrication points.
- ◆ Make sure to prevent material damage by putting certain measures in place in the case that the lubricator malfunctions.
- ◆ Operate the lubricator only when it is in perfect condition.
- ◆ Retrofitting, changing, or reconstructing the lubricator is not allowed. perma-tec must be consulted first.
- ◆ The LC unit should not be forced open.

2.3 Safety information for perma STAR CONTROL IMPULSE

2.3.1 Safety during installation and maintenance



- ◆ Ensure that all workstations and traffic routes are clean and safe!
- ◆ Ensure that the relevant regulations and guidelines are adhered to when the installation or maintenance work is carried out in places where danger of falling exists.
- ◆ Ensure that the relevant safety and operating instructions are observed when the lubricators are installed on machines or in factories (i.e. to stop the machine).

2.3.2 Safety when handling the LC unit



- ◆ Avoid contact of oil and grease with eyes, skin, and clothing!
- ◆ Avoid swallowing of oil and grease!
- ◆ Prevent oil and grease from getting into soil or sewer system!
- ◆ Observe safety data sheets of oils and greases! You may also download data sheets of lubricants supplied by perma-tec from perma-tec's web page (www.perma-tec.com) or ask your local supplier.
- ◆ Oil and grease on traffic ways will increase the danger of slipping! Therefore, immediately clean oil and grease from floors!
- ◆ Only use original LC units from perma-tec!

3 TECHNICAL DATA

3.1 Data sheet: power supply

3.1.1 Cable construction:

Conductor cross-sectional dimensions:	4 x 0.25 mm ²
Flexible cord construction:	Cu flex 32 x Ø 0,1 mm blk
Insulation:	PVC Ø 1.3 + 0.05 wall thickness abt. 0.32 mm
Cable covering:	PUR / black

3.1.2 Values

Line resistance:	79,9 Ω / km bei 20 °C (68 °F)
Safe temperature:	static condition: -25 to +70 °C (-13 to 158 °F) dynamic condition: -5 bis +70 °C (23 to 158 °F)
Output load	each max. 400 mA, short-circuit proof



Cable is drag chain qualified, approved for the smallest bending radius 60 mm.



Power supply 15 to 25 V DC (max. 30 V DC, 5% residual ripple) must be applied for the duration of the actual lubricant discharge process, in order to guarantee correct empty level signal.
Typical current consumption 0.2 A (current at make can be up to 1.2 A).
Max. output load (Pin 2 + 4) cannot exceed 400 mA each.

3.2 Product specifications

3.2.1 Pin assignment

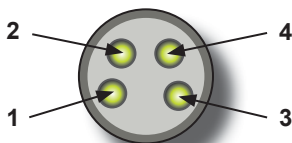

Pin assignment of the connector on the lubricator

Pin assignment	cable colour	signal
1	brown	current +
2	white	LED green digital
3	blue	current -
4	black	LED red digital

3.2.2 Components

- ◆ Lubricators are delivered as requested by the customer in regards to size, and oil or grease filling. They consist of (see Picture 1):
 - a) Plug
 - b) LC unit (Lubrication Canister), available with the requested lubricant and in three different sizes (thread size R1/4).
LC unit cannot be refilled!
 - c) Drive unit, consisting of a gear motor and circuit board for control of the lubricator. Every drive has an individual, consecutive series number (this number must be provided for all inquiries about the system).
Drive unit can be re-used.
 - d) LED function display
 - e) Cover (re-usable)
 - f) Cable with plug (re-usable)

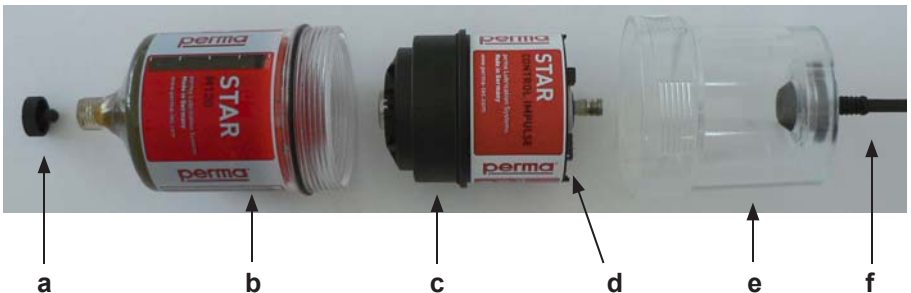

Pict. 1

3.2.3 Airborne noise emission

Emission sound pressure level of the lubrication system: < 70 dB(A)
(Measuring point: distance 1 m / height 1.6 m)

3.2.4 Function

Whenever external power (Impulse) is applied, the lubricator will discharge a set amount one time.

In the LC unit, a motor driven spindle pushes the lubricant out of the LC unit. The piston will move and, depending on the counter pressure, will build up pressure in the LC unit of up to 5 bar (75 psi). The automatic pressure shut off will turn the system OFF after several attempts when the pressure exceeds 5 bar.

With dip switch 3 and 4 of the 4-way code-switch on the circuit board (marked "VOL") you can set the size of the LC unit. With dip switch 1 and 2 (marked "TIME") you can set the discharge amount per impulse (see chapter 7.3).

3.3 Weights and measurements

Type	Volume [cm ³]	Diameter D [mm]	Total length L [mm]	Weight empty [kg]	Weight filled with SF01 [kg]
S60	60	71	142	0.310	0.360
M120	120	71	165	0.320	0.430
L250	250	71	215	0.360	0.590



3.4 Operating conditions

3.4.1 Temperatures

- ◆ Temperature range: -10 °C to $+50\text{ °C}$ ($+14\text{ °F}$ to $+122\text{ °F}$)
- ◆ Within this temperature range, a regular discharge and a max. output pressure up to 5 bar (75 psi) is guaranteed.
- ◆ For temperatures higher than $+50\text{ °C}$ ($+122\text{ °F}$) and lower than -10 °C ($+14\text{ °F}$) the correct function can no longer be guaranteed.

3.3.2 Ambient conditions

- ◆ The lubricators are protected against dust and water jets when the individual parts are assembled correctly.
- ◆ Ambient media, especially chemically aggressive substances, may affect sealing rings and plastic materials.

4 STORAGE

4.1 General storage information

When the lubricators are not immediately installed, you must ensure appropriate storage conditions in dry, dust free, sunlight-protected rooms indoors.

4.1.1 Storage conditions

- ◆ Dry
- ◆ Dust free
- ◆ Temperature $+20\text{ °C} \pm 5\text{ °C}$ ($+68\text{ °F} \pm 9\text{ °F}$)

4.1.2 Storage periods

- ◆ Up to one year
 - LC unit: refer to filling date i. e. 03/06 = June 2003
- ◆ Up to two years
 - Drive unit
 - Drive unit cover
 - Cable and plug

5 STARTING AND OPERATING

5.1 Preparation



Before installing the lubricator, the lubrication points and any extensions must be adequately pre-lubricated with the same lubricant which is contained in the perma STAR CONTROL IMPULSE.

For this purpose, perma-tec offers a 400 g lubricant cartridge for grease guns (see chapter 10.1).

- ◆ Please use a STAR support flange G1/4a x G1/4i (brass/plastic) from perma-tec for the installation of perma STAR CONTROL IMPULSE.
- ◆ For horizontal mounting positions we recommend the clip (plastic) to hold the lubricator in place.

The perma STAR installation instructions provide support for mounting of the lubricators and can be downloaded from our homepage.

5.2 Before operation

- ◆ Completely check the lubricator for visible damages!
- ◆ Check if the LC unit is filled with the requested grease or oil!
- ◆ Do “VOL” switches 3+4 of the four-way code switch in the drive unit match the correct size of the LC unit (see chapter 7.3)?
- ◆ Do “TIME” switches 1+2 of the four-way code switch in the drive unit match the desired discharge period (see chapter 7.3)?
- ◆ Oil-filled LC units: Check if an oil throttle is attached.
- ◆ Were all components properly assembled and screwed together hand-tight?
- ◆ Ensure that the cable is plugged into the perma STAR CONTROL IMPULSE.

5.3 Initial operation

- ◆ perma STAR CONTROL IMPULSE is delivered with a pre-set discharge period of 6 months and the LC unit M120 (standard setting).
- ◆ On request, we can pre-set the discharge amount or discharge mode according to your requirements.



Regardless of which option you choose, the operator must check the setting again and carry out any desired changes before starting the lubricator (see chapter 7)!

- ◆ Pre-lubricate the lubrication point with the same lubricant that is contained in the perma STAR CONTROL IMPULSE (see chapter 5.1).
- ◆ Check if the thread of the LC - unit corresponds to the thread of the screw point (R1/4).
- ◆ In the switch cabinet, connect the cable according to the PLC-wiring diagram for the status display. The connection may only be carried out by qualified experts and must be carried out according to local standards (i. e. IEC, VDE etc.).



NOTE: Incorrect connection of the perma STAR CONTROL IMPULSE could destroy the electronics.

- ◆ Unscrew and remove the cover of the drive unit. Set the dip switches 1- 4 (“TIME” and “VOL”) of the 4-way code switch according to your calculations (see chapter 7.3). Place cover back on drive unit and remove the plug from the LC unit. Screw perma STAR CONTROL IMPULSE onto the lubrication point (handtight). Never screw in the lubricator a second time as this would impair the self-sealing of the thread. Plug the cable into the connection on perma STAR CONTROL IMPULSE.
- ◆ Seal threads of all connecting parts with a suitable, standard sealant. Ensure that oil filled lubricators are mounted (max. $\pm 45^\circ$) vertically (outlet pointing down).
- ◆ As soon as power is applied, the first discharge will take place.

5.4 During operation

- ◆ Carry out regular performance checks during operation.
Check for possible leakages and the status of the lubricator!
- ◆ Regularly monitor the fill-level of the transparent LC unit!
- ◆ In case of malfunctions during operation, please check the trouble shooting chart in chapter 8. If the malfunction cannot be corrected, please contract your perma distributor.



Please make sure to refer to point 7.3.1 if the settings must be changed after the perma STAR CONTROL IMPULSE was already put into operation.

6 CHANGING THE LC - UNIT

6.1 General note

When the red and the green LED light up at the same time, the LC unit is empty and should be replaced.

During the LC unit exchange, it is possible to choose a different size and a different discharge period by resetting the dip switches of the 4-way code switch on the circuit board.

Since the drive unit and the circuit board must always be protected from moisture, the exchange must be carried out in a dry place!

6.2 How to change the LC - unit

- a) Unplug the cable from the perma STAR CONTROL IMPULSE.
- b) Completely screw off and remove the lubricator from the lubrication point.
- c) Unscrew the cover from the drive unit.
- d) Remove the drive unit from the LC unit.
- e) Dip switches of the 4-way code switch should be changed in cases where a different size LC unit was used, or if a different discharge period is desired (see chapter 7.3.1).
- f) Place drive unit on top of new LC unit until the teeth of both units are locked.
- g) Screw the cover of the drive unit onto the LC unit hand-tight.
- h) Remove plug from the LC unit.
- i) Screw the lubricator into the lubrication point hand-tight, but DO NOT screw it in a second time.
- j) For oil filled lubricators, make sure that the lubricator is installed (max. $\pm 45^\circ$) vertically (outlet pointing down).
- k) Plug cable back into the perma STAR CONTROL IMPULSE.

Please note that the warranty will expire if above instructions are not followed.

7 DRIVE UNIT SETTINGS

7.1 Function display

The LEDs (Light Emitting Diodes) are on the circuit board and are visible through the transparent cover (see picture 2, chapter 7.2).

The perma STAR CONTROL IMPULSE has a red and green LED. The following signals about operating conditions/ malfunctions are displayed by the LED for the user:

LED	Signal	Meaning
green	steady	System functions OK
red	steady for less than 30 seconds with motor run	STAR CONTROL IMPULSE is discharging
red	steady signal for more than 30 seconds	Malfunction/Error
green and red	steady signal	LC unit empty, please change

7.2 Circuit board settings

The 4-way code switch is located on the circuit board.

Dip switches 1+2 marked "TIME" are used to set the discharge amount, dip switches 3+4 marked "VOL" are used to set the LC unit size.

You may set/change the switches with the help of a small screw driver or with your fingers.

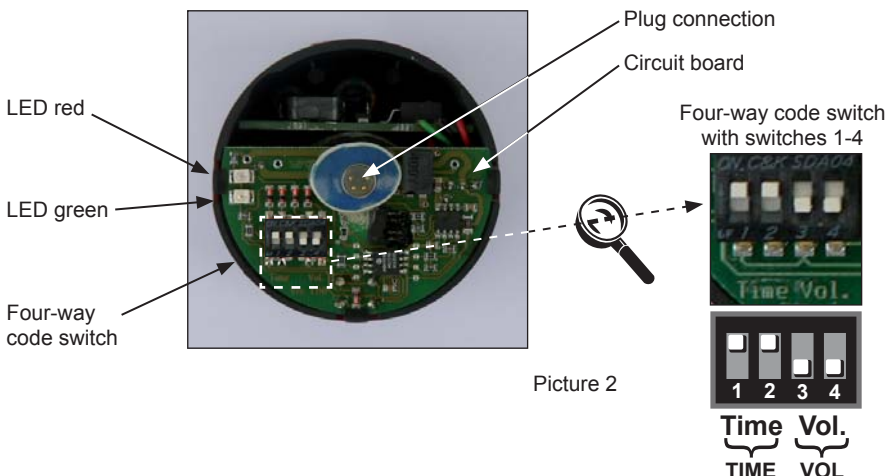

Picture 2

7.2.1 Setting the discharge amount

The lubricant amount per impulse must be set with dip switches 1+2 “TIME” of the 4-way code switch located on the circuit board of the drive unit.



If the position of code switches 1+2 “TIME” of the 4-way code switch does not correspond to the desired discharge amount (see chapter 7.3), it will lead to wrong signals and to over- or under lubrication (see chapter 8).

7.2.2 Setting volume of LC units

The LC unit size must be set with dip switches 3+4 “VOL” of the 4-way code switch located on the circuit board of the drive unit.



If the position of code switches 3+4 “VOL” of the 4-way code switch does not correspond to the actual size of the LC unit, it will lead to an incorrect signalling of fill level (see chapter 8).

Four-way code switch
with switches 1-4



TIME VOL







Time



Vol.

7.3 Table of discharge

Discharge amount in cc (1 cc ≈ 0.9 g lubricant)
per Impulse

Code switch LC unit	Vol. S60	Vol. M120	Vol. L250
 Time	2,11	2,11	2,11
 Time	1,06	1,06	1,06
 Time	0,53	0,53	0,53
 Time	0,26	0,26	0,26

Dip switches 3+4
“VOL” of the
4-way code switch

Dip switches 1+2
“TIME” of the
4-way code switch



As soon as power (15 to 25 V DC , max. 30 V DC) is supplied, the perma STAR CONTROL IMPULSE will discharge the set amount **once**. Power must be applied at least until this discharge has taken place (about 2 minutes).



In order to get **another** discharge cycle, the power must be **interrupted** for **at least 15 seconds** and then supplied again.

7.3.1 Changing the discharge volume after the perma STAR CONTROL IMPULSE has been in operation/reset function

With the reset-function, the lubricator can be returned to its initial state by resetting the internally saved parameters.

- a) Unplug the power plug from the lubricator.
- b) Unscrew the lubricator from the lubrication point.
- c) Unscrew the LC unit from the drive unit.
- d) Put dip switches 3+4 "VOL" of the 4-way code switch to this position (Reset). → 
- e) Attach the power connector to the drive unit.
- f) As soon as the motor has run for 2 sec, both LED's will light up. Pull the plug from the drive unit.
- g) Set dip switches "TIME" and "VOL" of the 4-way code switch according to chapter 7.3.
- h) Again, push and hold the white peg on the bottom of the drive unit (see picture below).
- i) Attach the power connector to the drive unit.
- j) After 3 seconds, release the peg and unplug the power connector.
- k) Mount the drive as described under **point 6.2**.

NOTE: Changing the discharge volume as described above may result in an incorrect LED display of "LC unit empty" which depends on how empty the attached LC unit was before the discharge volume was changed. Therefore it is important that you manually monitor the End of discharge period.



8 TROUBLE SHOOTING

In case of malfunctions during operation, please check the following chart for possible causes and corrective actions. If the malfunction is not listed, please contact your perma distributor.

Malfunctions	Possible cause	Solution
perma STAR CONTROL IMPULSE does not function	<ul style="list-style-type: none"> - Wrong cable connection - Break in cable - No power supply - Relay defect in machine 	<p>Connect cable according to pin assignment. Check pin assignment</p> <p>Check voltage at plug, attach new cable</p> <p>Check power supply. Too many perma STAR CONTROL IMPULSE attached for power supply used.</p> <p>Change relays</p>
perma STAR CONTROL IMPULSE signals "system functions OK" (green LED), although LC unit is empty.	<ul style="list-style-type: none"> - Setting of "VOL" switch different than attached LC unit - Partly filled LC unit was replaced by an almost empty LC unit 	Replace with full LC unit
perma STAR CONTROL IMPULSE signals "system malfunctions" (red LED)	<ul style="list-style-type: none"> - Clogged tube and/or connection parts - Counter pressure too high 	Clean tube and connecting parts, then shut off and restart perma STAR CONTROL IMPULSE (refer to chapter 7.3.1)
perma STAR CONTROL IMPULSE discharges too fast	<ul style="list-style-type: none"> -Wrong position of "TIME" switch 	Correct switch setting (refer to chapter 7.3.1)
perma STAR CONTROL IMPULSE signals "end of discharge" (red and green LED), although the unit is not empty	<ul style="list-style-type: none"> - Setting of "VOL" switch different than attached LC unit - Almost empty LC unit was replaced by a partly filled LC unit - Reset-peg was not pushed down during assembly 	<p>Replace with full LC unit</p> <p>Move drive unit a few teeth so that reset-peg is pushed down.</p>
perma STAR CONTROL IMPULSE does not discharge the correct amount	<ul style="list-style-type: none"> - Changing of the Dip-switch-setting was done incorrectly 	Refer to chapter 7.3.1

9 DISPOSAL



Help us in protecting the environment and saving resources by recycling valuable raw material. Please follow the individual waste disposal regulations in your country.

10 ACCESSORIES FOR perma STAR CONTROL IMPULSE



Accessories and replacement parts must meet the technical requirements. This can be guaranteed by using original parts from perma-tec.

10.1 Accessories

- ◆ STAR CONTROL Cable (5 m) part no. 26 004 001
(10 m) part no. 26 004 004
- ◆ STAR support flange G1/4a x G1/4i (brass/plastic) part no. 26 001 620
STAR support flange 1/4" NPT (brass/plastic) part no. 26 001 621
- ◆ Clip (plastic) part no. 26 001 105
- ◆ Bracket (stainless steel) part no. 26 00012 150 with insert for bracket G1/4a x G1/4i (brass) part no. 26 0011 151 or oil throttle up to +60 °C (brass with plastic-valve) part no. 26 0011 810
- ◆ 400 g grease cartridge or oil container
- ◆ Lubrication Maintenance Plan
- ◆ Additional accessories on request

10.2 Replacement parts

- ◆ LC unit (thread R1/4) in size:
 - S60 (60 cc)
 - M120 (120 cc)
 - L250 (250 cc)
- ◆ Drive unit
- ◆ Cover for drive unit (part no. 72 102 002)

11 SERVICE

Please contact your local supplier for availability and cost of the following:

- ◆ Returning of the empty lubricator for environmentally safe recycling or disposal.
or:
- ◆ exchange the LC unit
- ◆ setting the desired discharge amount

12.1 Suggestion for PLC connection with one output signal

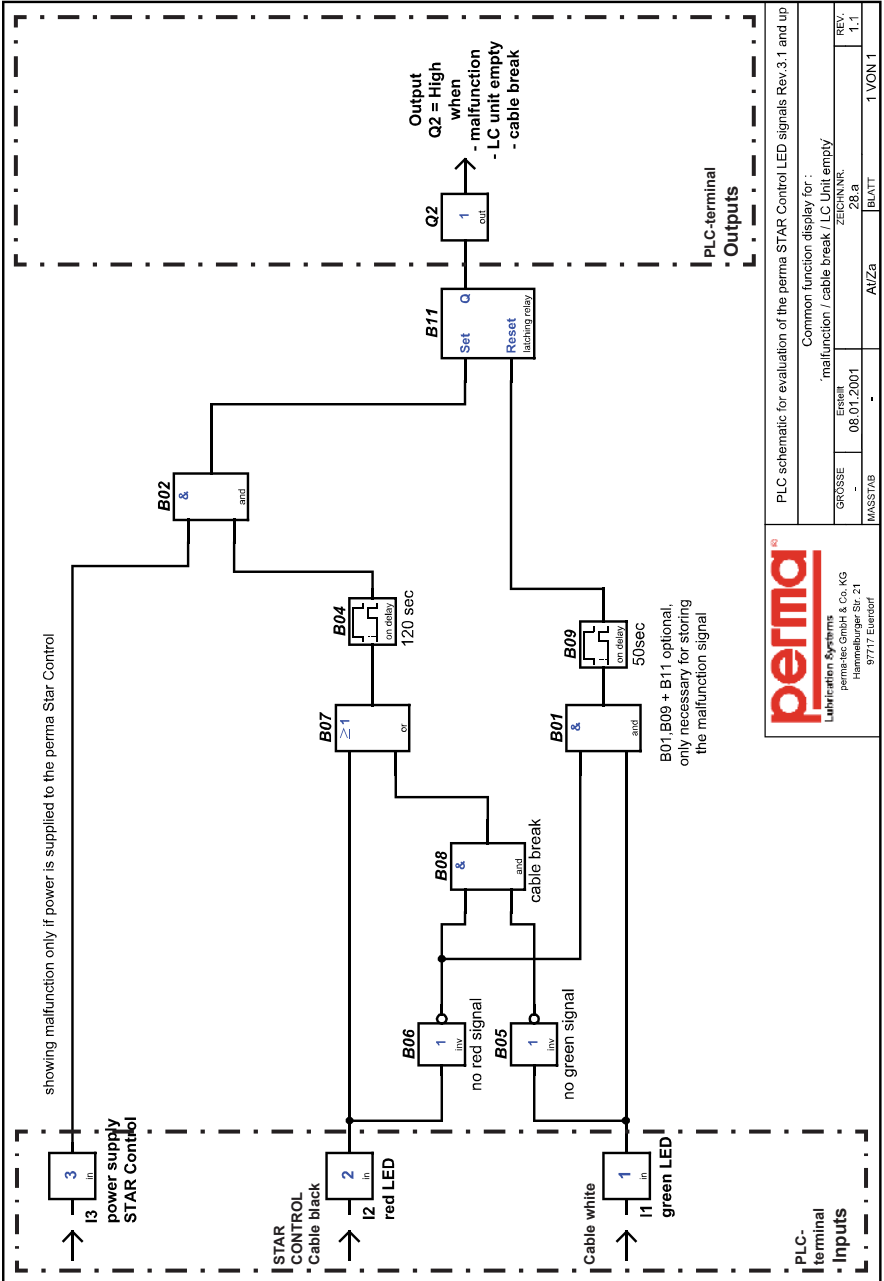

PLC schematic for evaluation of the perma STAR Control LED signals Rev.3.1 and up

Common function display for:	
Erweit.	malfunction / cable break / LC Unit empty
GROSSE	ZEICHNR.
-	28-a
08.01.2001	REV.
MASSSTAB	BLATT
-	1 VON 1
-	1.1

12.2 Suggestion for PLC connection with two output signals

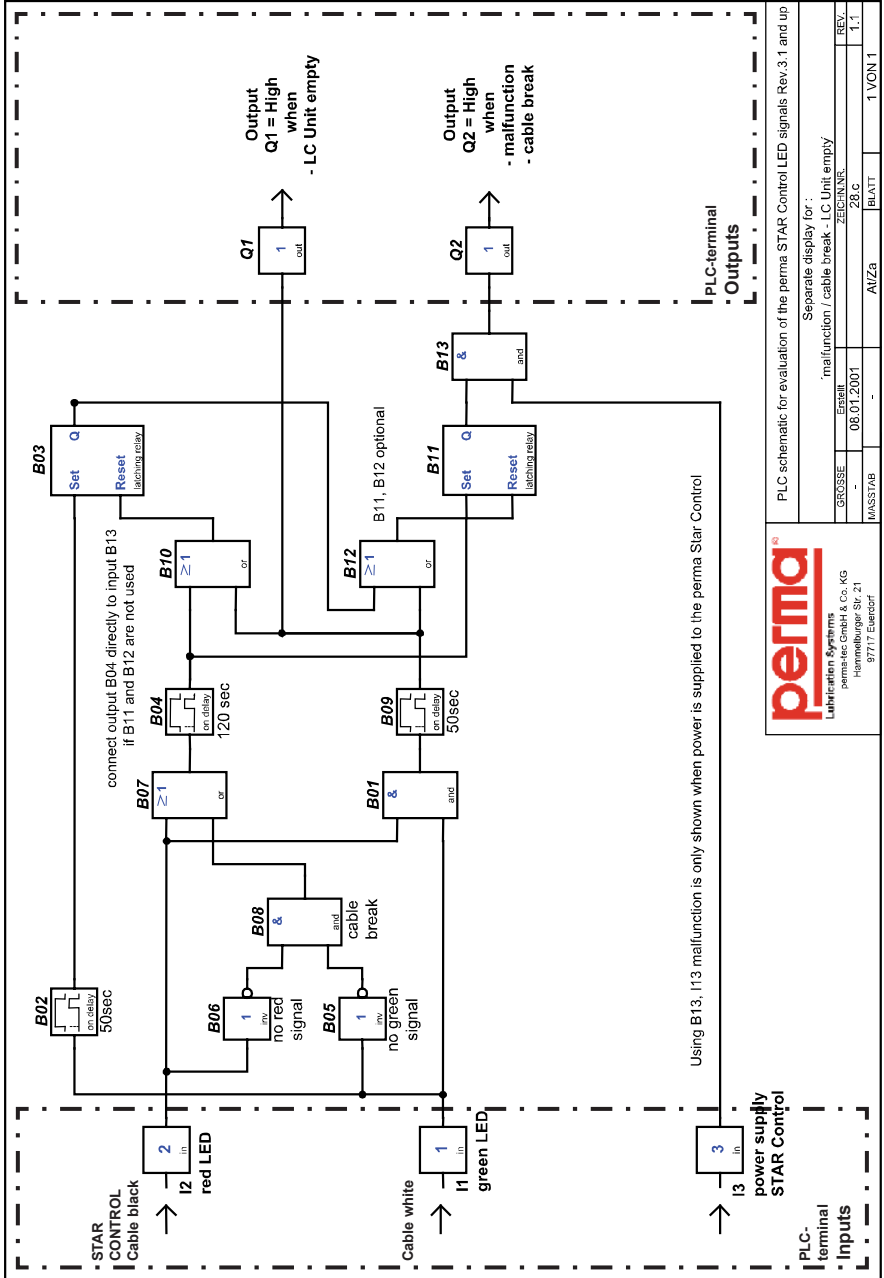

12.3 Suggestion for PLC connection with three output signals

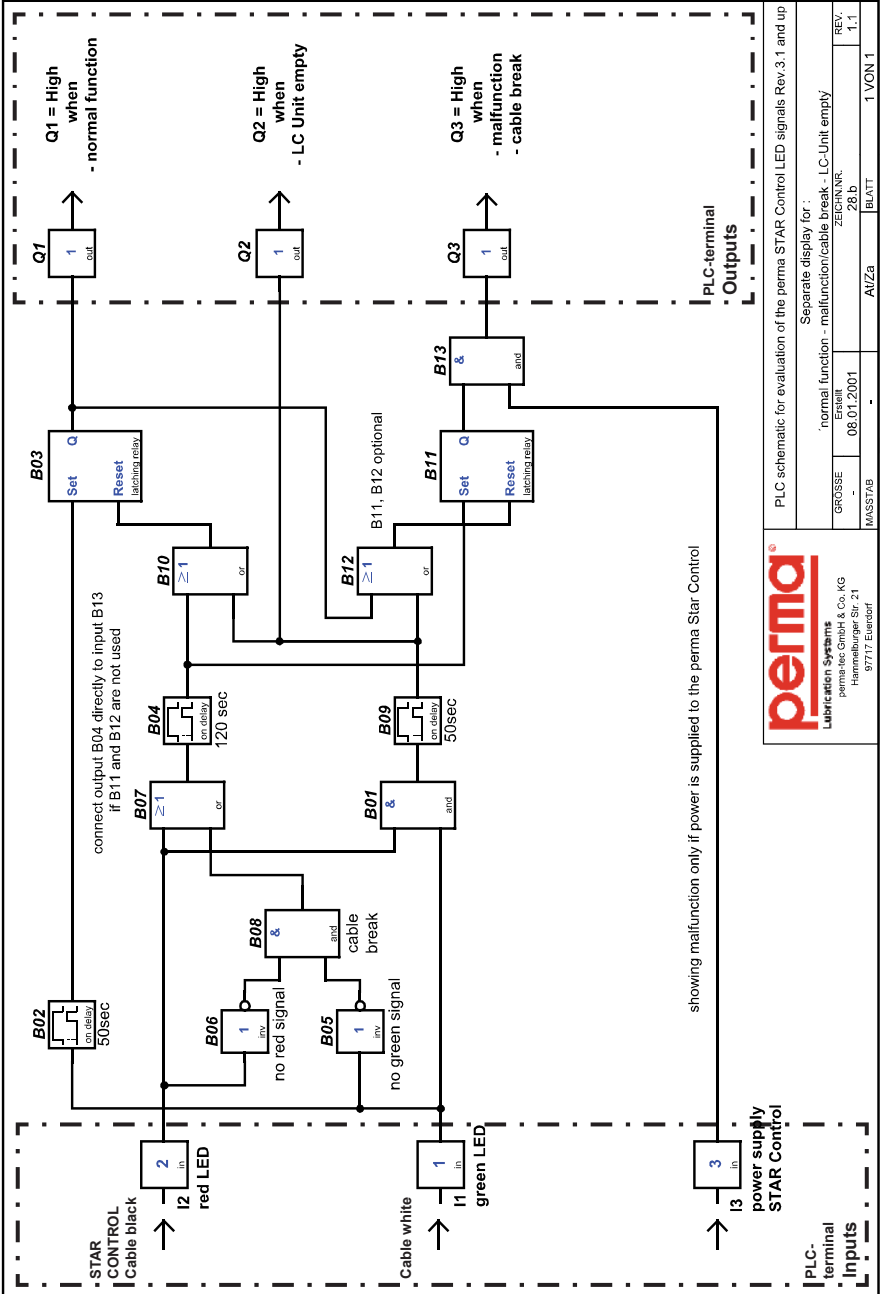

PLC schematic for evaluation of the perma STAR Control LED signals Rev.3.1 and up

Separate display for :

GROSSE	normal function - malfunction/cable break - LC-Unit empty
ZEICHN.NR.	Ersellt
28.b	08.01.2001
REVISION	1.1
MASSTAB	1:1
Blatt	1 VON 1

EC Declaration of Conformity

- according to the Machinery Directive 98/37/EC^[1] and according to EMV (Electromagnetic Compatibility) – Directive 2004/108/EC.
- according to the Machinery Directive 2006/42/EC^[2] and according to EMV (Electromagnetic Compatibility) – Directive 2004/108/EC.

The manufacturer

perma-tec GmbH & Co. KG
Hammelburger Straße 21
97717 Euerdorf, Germany

hereby declares that the product as described in the given statement conforms to the regulations appertaining to the directives referred to above, including any amendments thereto which are in force at the time of the declaration.

Product description: Automatic lubrication system
Product name: perma STAR CONTROL IMPULSE
Type: S60, M120 and L250

The following harmonised standards were applied:

- EN ISO 12100 – 1:2003 Safety of machinery – basic concepts, general terms of reference as regards design and construction – Section 1: Basic Terminology, Methodology
- EN ISO 12100 – 2:2003 Safety of machinery – basic concepts, general terms of reference as regards design and construction – Section 2: Technical terms of reference
- EN 60204 – 1:2006 Machinery's electrical equipment

Euerdorf, 11 February 2009

perma-tec GmbH & Co. KG

Walter Graf, Managing Director Egon Eisenbacher, Technical Management
and authorized documentation representative
(see manufacturer address)

This declaration certifies conformity to the directives referred to but it is not a warranty of qualities. The safety instructions of the operating manual are to be observed.

1. Directive 98/37/EC is valid until and including the 28th of December 2009.
2. Directive 2006/42/EC is valid as of 29 December 2009.

Notes:

perma-tec GmbH & Co. KG
Hammelburger Str. 21
97717 Euerdorf

Germany

Tel: +49 (0) 9704 609-0

Fax: +49 (0) 9704 609-50

E-mail: info@perma-tec.com

Homepage: www.perma-tec.com