

**perma-tec**  
GmbH & Co. KG

Internet: [www.perma-tec.com](http://www.perma-tec.com)

**perma**<sup>®</sup>

# OGL-SYSTEM

Open Gear Lubrication-System



Product specs subject to change 22 / 06 / 04

When used with a perma lubricator, the OGL system continually supplies open gear teeth with the correct amount and type of lubricant. The special lubricant is applied through the open gear's own rotating motion. The lubricant channels inside the applicator paddle spread the lubricant evenly over the surface of the teeth. When mounting the OGL system, the following points must be considered (in addition to general safety regulations):

### Mounting



First, locate a suitable place to mount the system so that the OGL cannot be damaged by other machine parts. Please consider the full range of motion of the applicator paddle.

The flexible tip of the paddle must be mounted  $0.6\text{in} \pm 0.04\text{in}$  ( $15\text{mm} \pm 1\text{mm}$ ) into the gap between the teeth. When in the relaxed state, the OGL system must be angled directly towards the focal point of the gear wheel (see Picture 1).

The mounting distance from the tip of the gear tooth to the tip of the applicator paddle must be  $0.6\text{in} \pm 0.04\text{in}$  ( $15\text{mm} \pm 1\text{mm}$ )

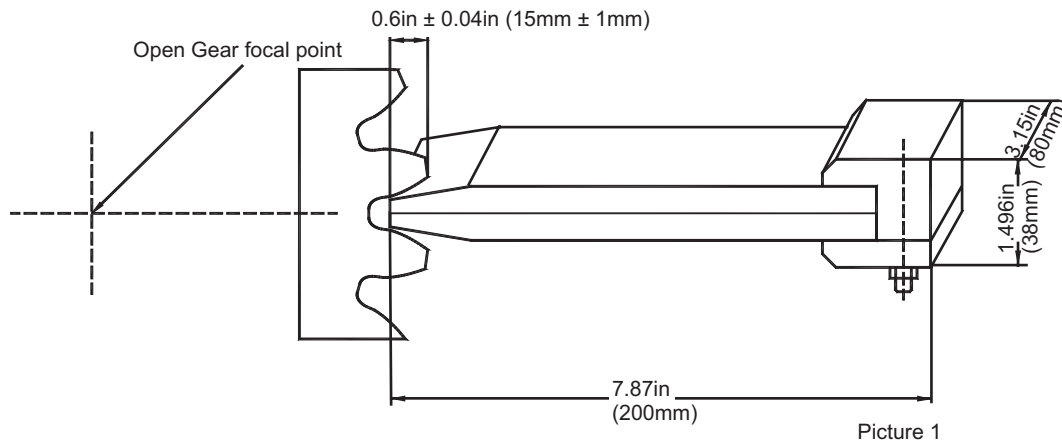

With gear wheel teeth wider than the width of the paddle (3.15in / 80mm), the OGL system should always be mounted in the center. With even wider teeth, two OGL systems can be mounted side by side. In this case, each OGL system would need its own perma lubricator.

To fasten the OGL system, you need to use two socket head screws M6x45 (see Picture 2).

### Lubricator



The perma lubricator can be attached directly to the metal bracket on the OGL system (G1/4 thread). If this is not possible, you may use an extension tube 8x1 mm with a 3 ft maximum tube length. Both the tubing and the applicator paddle must be pre-filled with the same lubricant that is in the perma lubricator. The OGL system works in any position - just like the perma lubricator.

### Assembly of the OGL-System Part No. 27.007.000

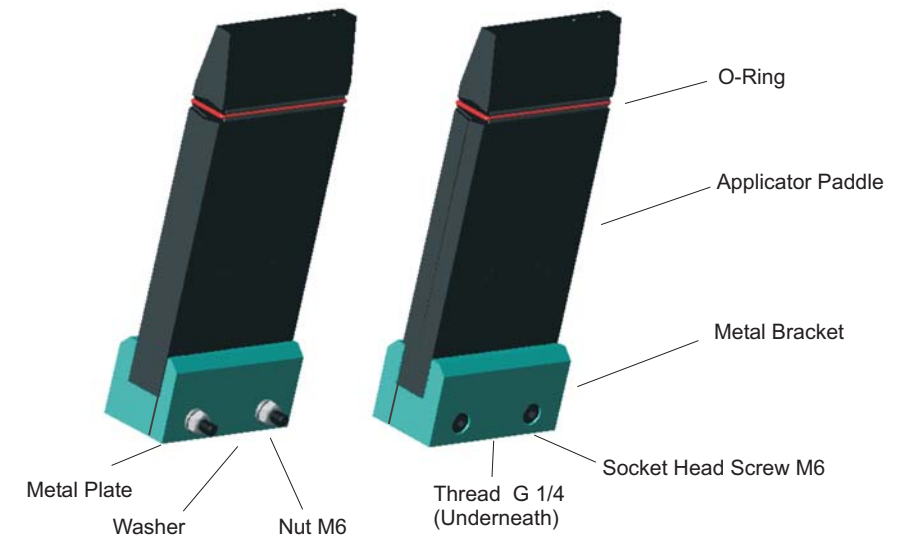

### Technical Data

Gearwheel speed  
Application temperature  
Application area  
Lubricants

$v_{\max} = 6\text{ m/min} \sim 0,1\text{ m/s}$   
 $0^{\circ} - 50^{\circ}\text{C}$  ( $32^{\circ} - 122^{\circ}\text{F}$ )  
open gears (Modul 10-14)  
suitable greases up to NLGI 2