

2

1

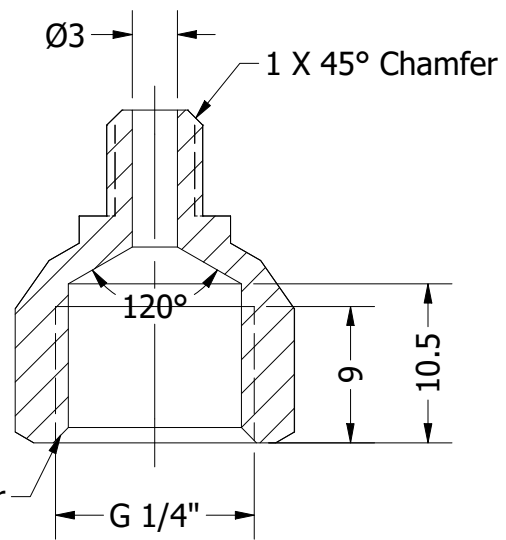
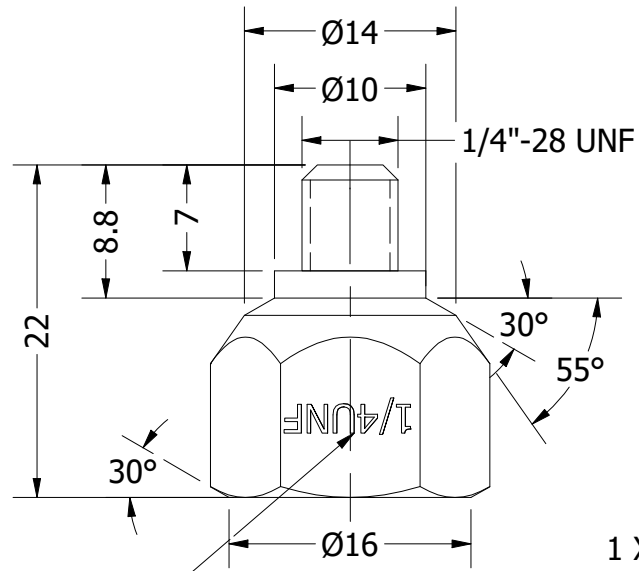

SECTION A-A

Laser Mark  
1/4UNF

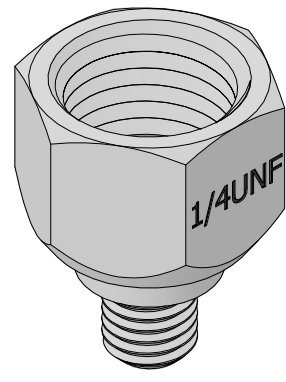
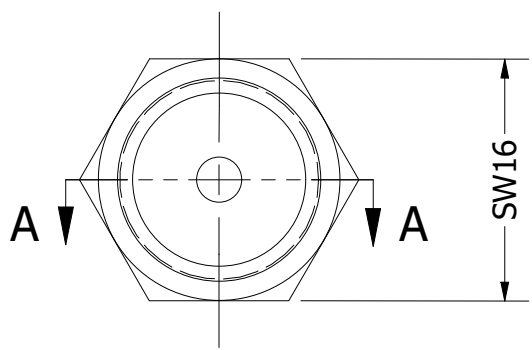

- NOTES:**
- Free of burrs and swarfs
  - No particles (greater than 0.2mm)
  - No Sharp Edges

PART NUMBER		DIMENSIONING AND TOLERANCING PER ASME Y14.5M-1994		ALL DIMENSIONS [mm.]		SCALE: 2 : 1	MAT: 316 Stainless Steel	
900495								
		DEPT	DATE	NAME		 H.T.L perma USA, L.P. 10333 Westlake Drive Charlotte, NC 28273 (704) 377-3100		
		A.E.	12.24.2024	K. Brooks				
		PROJECT				DESCRIPTION:		1 A
		Accessories				Reducer 1/4-28 UNF M x G1/4 F (SS)		
STATUS	REVISION	DATE	NAME	PREV DWG NUM: AX_RED_900495		DWG NUM: AX_RED_900495_B		

2

1