

2

1

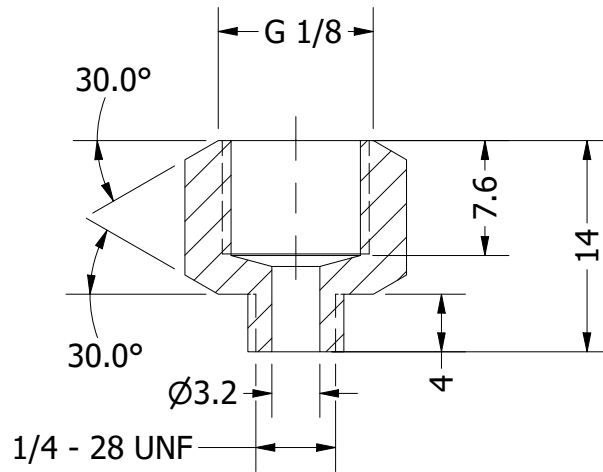

SECTION A-A
SCALE 2 : 1

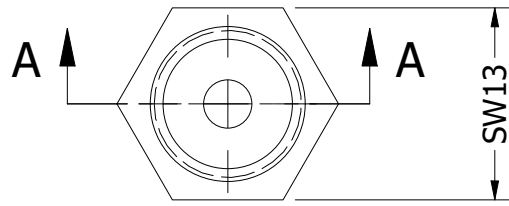
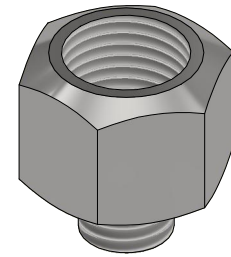

NOTES:

- Free of burrs and swarfs
- No particles (greater than 0.2mm)
- No Sharp Edges

PART NUMBER				DIMENSIONING AND TOLERANCING PER ASME Y14.5M-1994		ALL DIMENSIONS [mm.]		SCALE: 2 : 1		MAT:316 Stainless Steel	
912178											
				DEPT	DATE	NAME		 H.T.L perma USA, L.P. 10333 Westlake Dr Charlotte, NC 28273 (704) 377-3100			
				AE	6.29.2026	K.Brooks					
				PROJECT				DESCRIPTION:		1 A	
				Accessories				Reducer 1/4-28 UNF M x G1/8 F			
STATUS	REVISION	DATE	NAME	PREV DWG NUM: AX_RED_912178				DWG NUM: AX_RED_912178			

2

1