

2

1

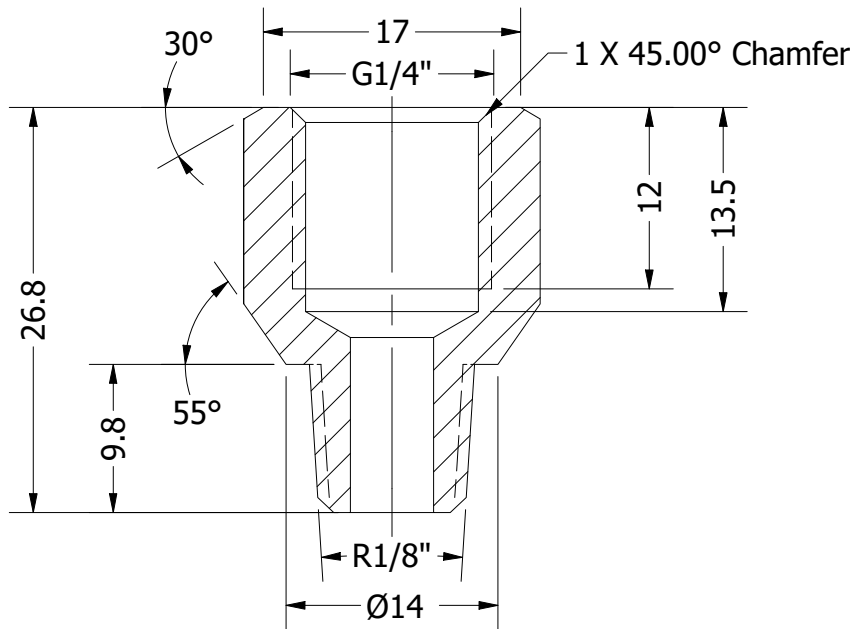

SECTION A-A

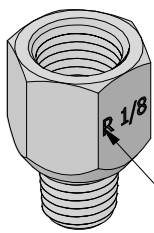

Laser Mark
R1/8

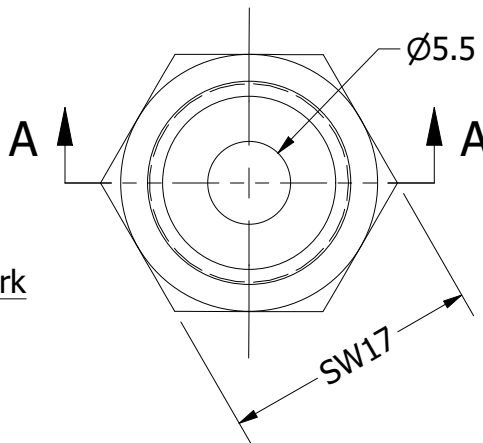

NOTES:

- Free of burrs and swarfs
- No particles (greater than 0.2mm)
- No Sharp Edges

PART NUMBER		DIMENSIONING AND TOLERANCING PER ASME Y14.5M-1994		ALL DIMENSIONS [mm.]		SCALE: 2 : 1		MAT:316 Stainless Steel	
900494									
			DEPT	DATE	NAME	 H.T.L perma USA, L.P. 10333 Westlake Drive Charlotte, NC 28273 (704) 377-3100			
			A.E.	12.27.2024	K.Brooks				
			PROJECT			DESCRIPTION:			1 A
			Accessories			Reducer R1/8 M x G1/4 F (SS)			
STATUS	REVISION	DATE	NAME	PREV DWG NUM: AX_RED_900494		DWG NUM: AX_RED_900494_B			

2

1